



- Containment level N2
- Working width: 0,7 m (W2)
- Dynamic deflection: 0,6 m
- ASI: A
- Post spacing 1,33 m
- Working length: 52 m (without ends)
- Efficiency point at 17 m from line start
- Deformed length (TB32): 6,79 m
- Hot dip galvanized (EN 1461)
- Width = 180 mm



**Duplex treatment available: hot-dip galvanization + powder coating**

**Quick and easy installation / Maintenance**

**NF certified transition with GBA-DBA**

**Made in France**

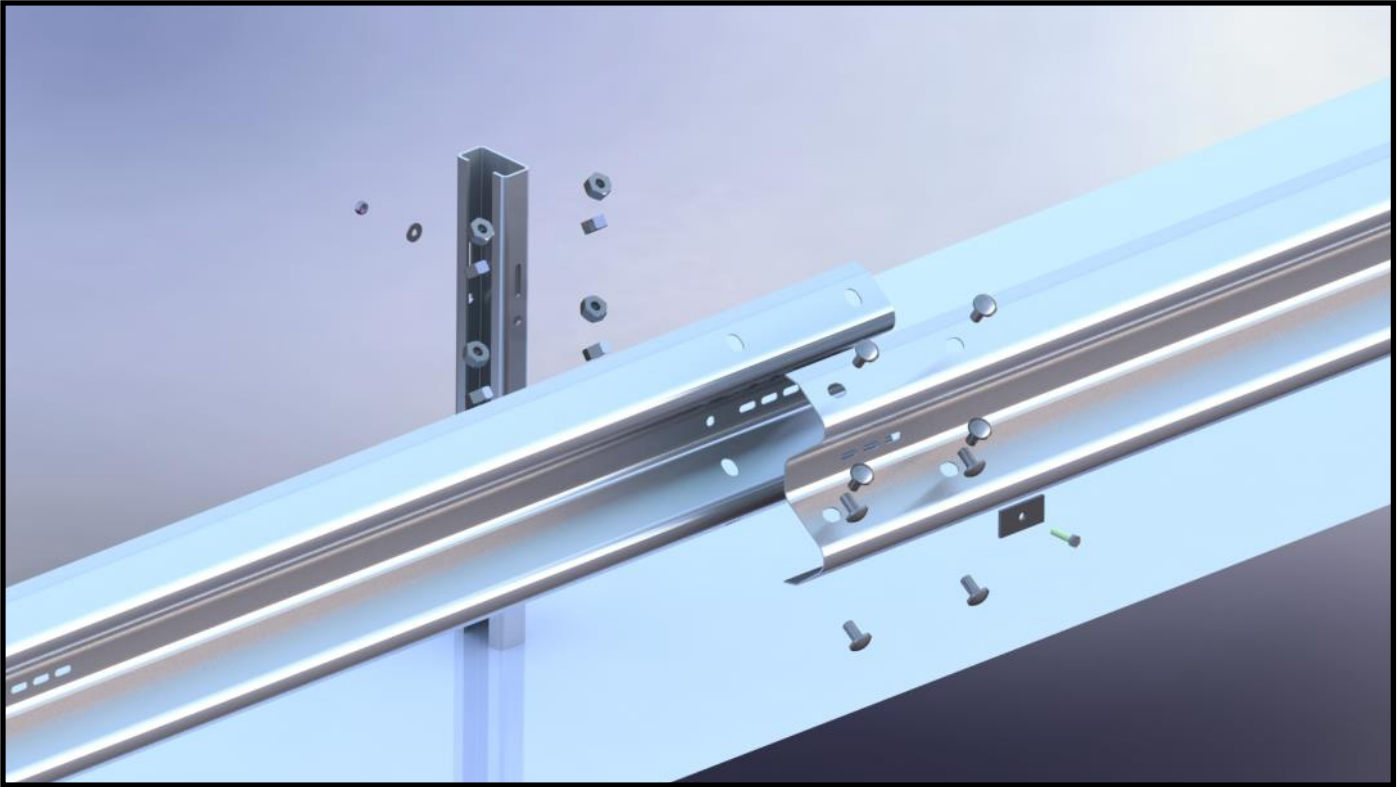

## Transition Euro GS N2-W2 to GBA-DBA

- Containment level N2
- Length: 11 m incl. 5 m on GBA-DBA
- Standard GBA-DBA line
- Standard GBA-DBA end (« TGV » shaped)
- No GBA-DBA soil housing needed



**Certified – NF 058 N° RACC-05–29**



ÉQUIPEMENTS DE LA ROUTE



ZI du Pont Panay  
03500 Saint-Pourçain-sur-Sioule  
Tél: +33 470 459 544  
Fax: +33 470 459 893  
Email: [lpc@galvaunion.com](mailto:lpc@galvaunion.com)  
Site internet: [www.roadis.fr](http://www.roadis.fr)

Certifié par  
BUREAU VERITAS  
Certification

